

COLUMBARIUM #2 DETAIL

COLUMBARIUM #1 DETAIL

RECHARGE SUITABILITY BORING
 SOIL LOG & INTERPRETATION - Form
 Municipality: West Long Branch, Boro
 1. Log Number: SB#2
 2. Soil Log
 Date: 5/30/14
 Method: Profile Pit (X) Boring
 Munsell Color Name & Symbol: Estimated Textural Class; Estimated Volume % Coarse Fragment, if present; Moist or Dry Consistence; Mottling - Abundance, Size & Contrast, if present

0" - 22" Dark brown (10YR 3/3) fine sandy loam
 22" - 30" Olive brown (2.5Y 4/4) fine loamy sand
 30" - 43" Light yellow brown (10YR 6/4) fine sand
 43" - 56" Olive brown (2.5Y 4/4) silty clay loam
 56" - 70" Olive (5Y 5/4) silty clay loam with many, medium, distinct strong brown (7.5YR 4/6) and pale olive (5Y 6/3) mottles at 56"
 70" - 84" Light olive brown (2.5Y 5/4) fine sand

3. Ground Water observations:
 (X) Seepage - Indicate Depth: 59"
 (X) Pie/Boring Flooded - Depth after 1.0 Hours: 59"

4. Soil Limiting Zones (Check Appropriate Categories):
 () Fractured Rock Substratum - Depth to Top
 () Excessively Coarse Substratum - Depth to Top
 () Excessively Coarse Substratum - Depth to Bottom
 () Hydraulically Restrictive Horizon - Depth to Top to Bottom 65/27
 () Hydraulically Restrictive Substratum - Depth to Top
 () Perched Zone of Saturation - Depth to Top to Bottom
 (X) Regional Zone of Saturation - Depth to Top 52"
 (A.K.A. SEASONAL HIGH WATERTABLE)

5. Soil Suitability Classification: J1Hy, J1Hy, J1Hy (Hydrologic group "B", Sheet #24, Monmouth County Soil Survey, K1ej (KUA))

6. I hereby certify that the information furnished on this form (and the attachments thereto) is true and accurate.

RECHARGE SUITABILITY BORING
 SOIL LOG & INTERPRETATION - Form
 Municipality: West Long Branch, Boro
 1. Log Number: SB#2
 2. Soil Log
 Date: 5/30/14
 Method: Profile Pit (X) Boring
 Munsell Color Name & Symbol: Estimated Textural Class; Estimated Volume % Coarse Fragment, if present; Moist or Dry Consistence; Mottling - Abundance, Size & Contrast, if present

0" - 19" Dark brown (10YR 3/3) fine sandy loam
 19" - 32" Olive brown (2.5Y 4/4) fine loamy sand
 32" - 46" Light yellow brown (10YR 6/4) fine sand
 46" - 57" Olive brown (2.5Y 4/4) silty clay loam
 57" - 61" Olive (5Y 5/4) silty clay loam with many, medium, distinct strong brown (7.5YR 4/6) and pale olive (5Y 6/3) mottles at 57"
 61" - 84" Light olive brown (2.5Y 5/4) fine sand

3. Ground Water observations:
 (X) Seepage - Indicate Depth: 59"
 (X) Pie/Boring Flooded - Depth after 1.0 Hours: 59"

4. Soil Limiting Zones (Check Appropriate Categories):
 () Fractured Rock Substratum - Depth to Top
 () Excessively Coarse Substratum - Depth to Top
 () Excessively Coarse Substratum - Depth to Bottom
 () Hydraulically Restrictive Horizon - Depth to Top to Bottom 65/27
 () Hydraulically Restrictive Substratum - Depth to Top
 () Perched Zone of Saturation - Depth to Top to Bottom
 (X) Regional Zone of Saturation - Depth to Top 52"
 (A.K.A. SEASONAL HIGH WATERTABLE)

5. Soil Suitability Classification: J1Hy, J1Hy, J1Hy (Hydrologic group "B", Sheet #24, Monmouth County Soil Survey, K1ej (KUA))

6. I hereby certify that the information furnished on this form (and the attachments thereto) is true and accurate.

RECHARGE SUITABILITY BORING
 SOIL LOG & INTERPRETATION - Form
 Municipality: West Long Branch, Boro
 1. Log Number: SB#1
 2. Soil Log
 Date: 5/30/14
 Method: Profile Pit (X) Boring
 Munsell Color Name & Symbol: Estimated Textural Class; Estimated Volume % Coarse Fragment, if present; Moist or Dry Consistence; Mottling - Abundance, Size & Contrast, if present

0" - 13" Dark brown (10YR 3/3) fine sandy loam
 13" - 23" Yellow brown (10YR 5/4) fine loamy sand
 23" - 35" Light yellow brown (10YR 6/4) fine sand
 35" - 49" Yellow (10YR 7/6) fine sand
 49" - 63" Olive brown (2.5Y 4/4) silty clay loam with many, medium, distinct strong brown (7.5YR 4/6) and pale olive (5Y 6/3) mottles at 49"
 63" - 84" Light olive brown (2.5Y 5/4) fine and medium sand

3. Ground Water observations:
 (X) Seepage - Indicate Depth: 59"
 (X) Pie/Boring Flooded - Depth after 1.0 Hours: 59"

4. Soil Limiting Zones (Check Appropriate Categories):
 () Fractured Rock Substratum - Depth to Top
 () Excessively Coarse Substratum - Depth to Top
 () Hydraulically Restrictive Substratum - Depth to Top
 () Perched Zone of Saturation - Depth to Top to Bottom
 () Massive Rock Substratum - Depth to Top
 () Excessively Coarse Substratum - Depth to Top
 () Hydraulically Restrictive Substratum - Depth to Top
 () Regional Zone of Saturation - Depth to Top 49"
 (A.K.A. SEASONAL HIGH WATERTABLE)

5. Soil Suitability Classification: J1Hy, J1Hy, J1Hy (Hydrologic group "B", Sheet #24, Monmouth County Soil Survey, K1ej (KUA))

6. I hereby certify that the information furnished on this form (and the attachments thereto) is true and accurate.

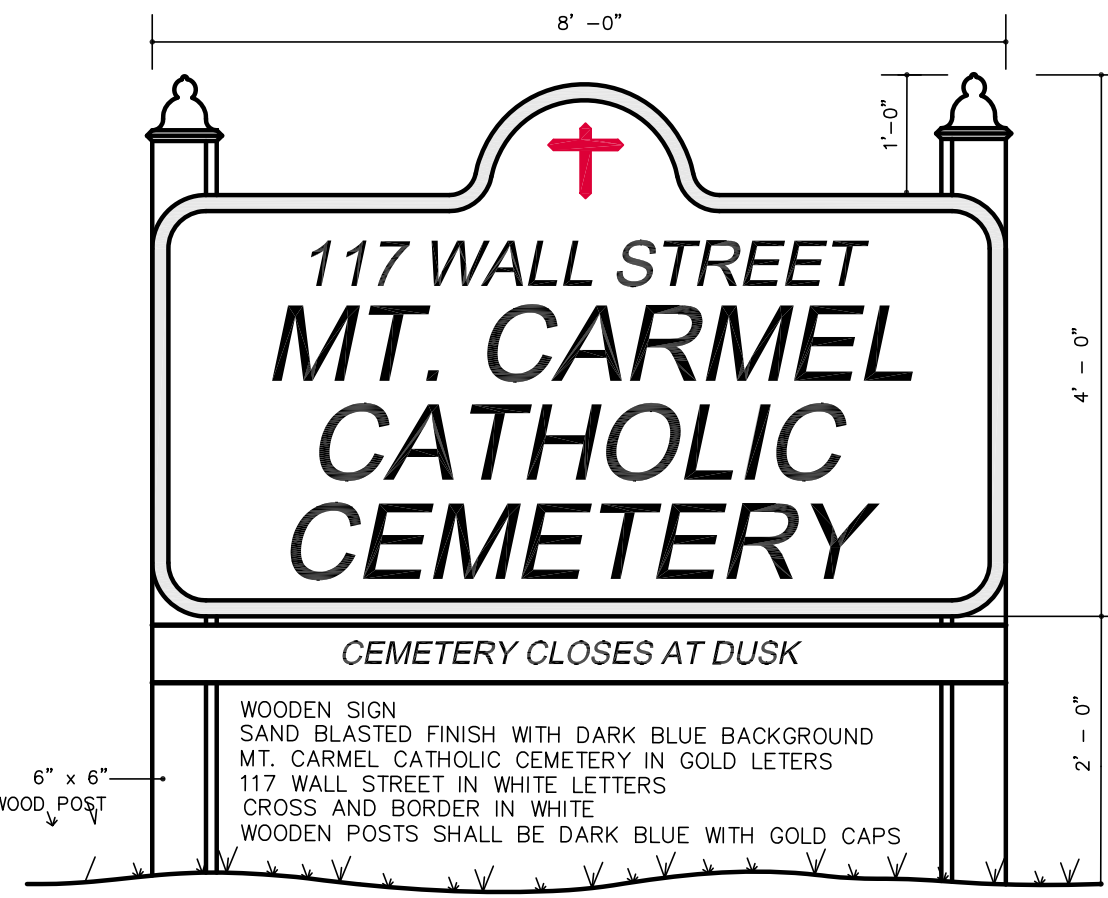

PROPOSED I.D. SIGN DETAIL

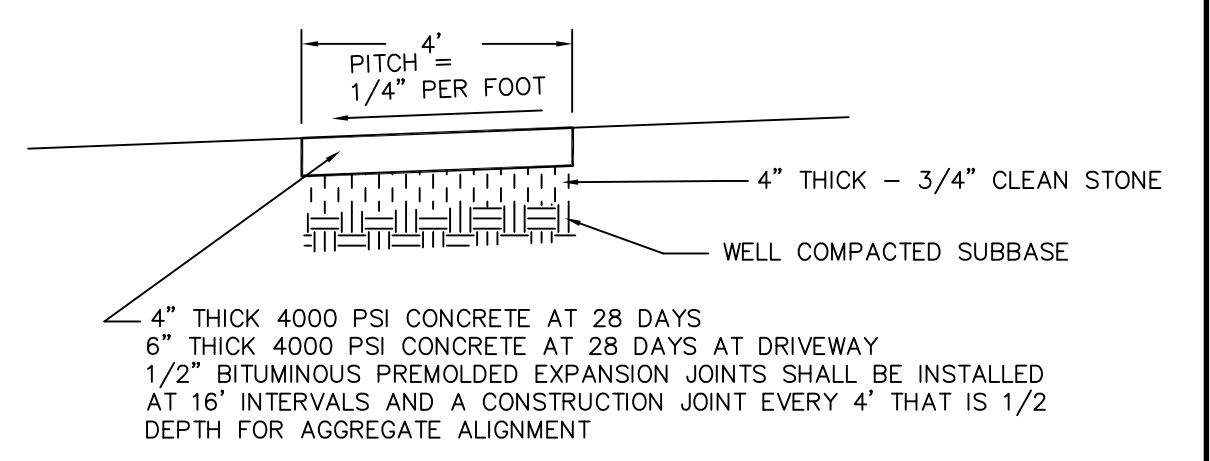

TYPICAL CONCRETE SIDEWALK DETAIL

3	REVISIONS AS PER BOROUGH BOARD MEETING OF 10/22/20	10/26/20	TG
2	REVISE AS PER BOROUGH ENGINEER AND BOROUGH PLANNER	08/31/2020	TG
1	REVISE COLUMBARIUM TO INCLUDE GAZEBO	1/31/2020	TG
REV.	DESCRIPTION	DATE	BY

DETAIL SHEET FOR PRELIMINARY/FINAL SITE PLAN APPL
 LOTS 21, 22, 23, 24, 25 & 26 BLOCK 15
 113, 115, 117, 119 & 121 WALL STREET
 on T.M. SHEET 9
 BOROUGH OF WEST LONG BRANCH
 MONMOUTH COUNTY NEW JERSEY

LANDMARK
 SURVEYING AND ENGINEERING, INC.
 813 Main Street
 Avon-by-the-Sea, New Jersey 07717
 Tel: (732)775-8558 - Fax: (732)775-7848
 Email: Landmarkse@Optimum.net
 Web: www.Landmarkse.net

DANIEL W. CARUSO, P.E.
 N.J. PROFESSIONAL ENGINEER - GE35687

SCALE: AS NOTED DATE: 11/26/19
 BY: SHEET # DRAWING: 5 OF 11 14021BOROUGH SITE PLAN 10-26-20

SOIL LOG #3

SOIL LOG #2

SOIL LOG #1